

# *TURNING TARGET SYSTEM*

---

## Assembly Instructions



### **STOP:**

If anything is missing from this package, or you have questions about assembly, please contact Challenge Targets directly for prompt assistance.

Challenge Targets

Phone: 1-800-859-5841 ext# 915

Email: [service@challengetargets.com](mailto:service@challengetargets.com)

***PATENT PENDING***



# Package Contents

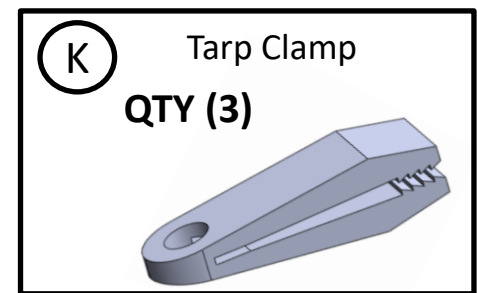
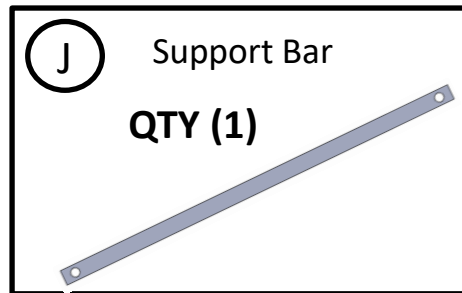
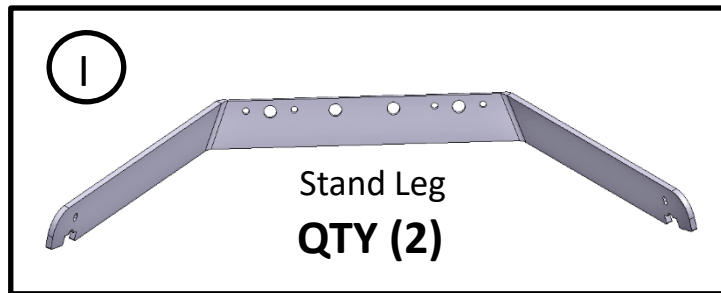
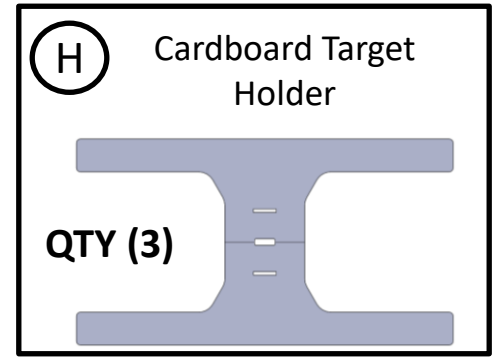
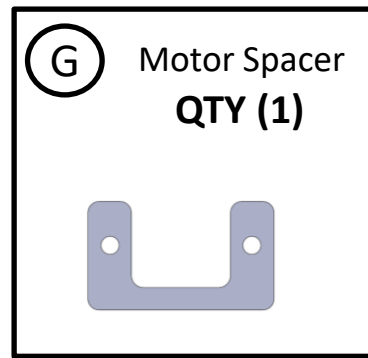
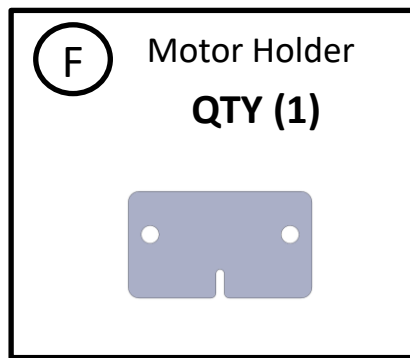
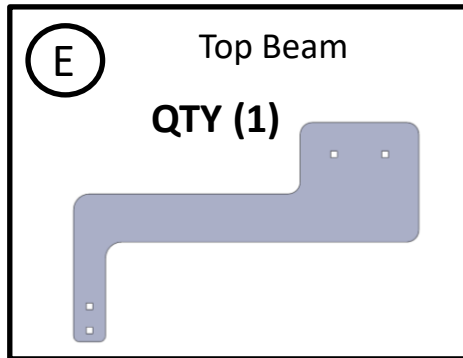
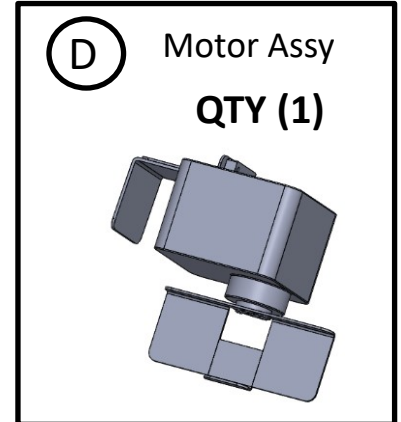
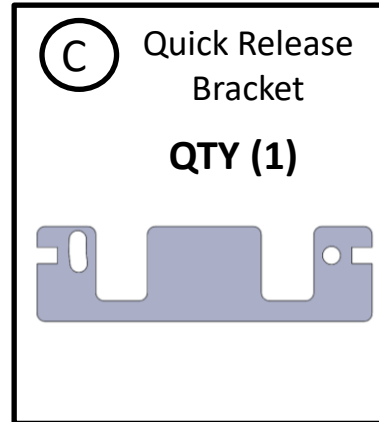
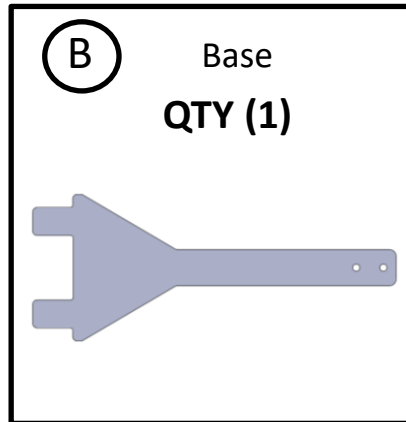
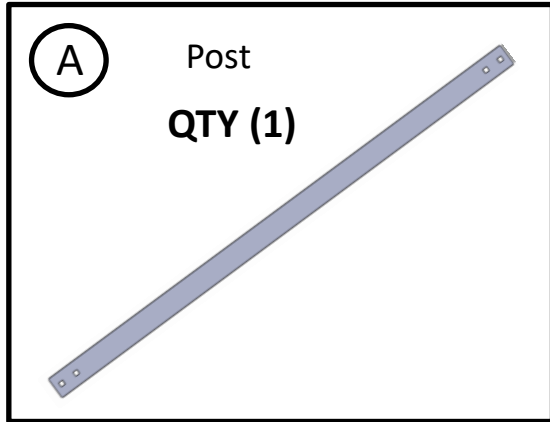

# Package Contents

**L** 1/4"-20 Bolt  
**QTY (4)**



**M** Stake Pad  
**QTY (4)**

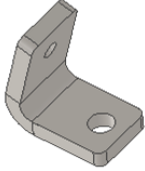

**N** 1/2"-13 x 1-1/2"  
Hex Head Bolt  
**QTY (2)**



**O** 1/2"-13 Nylon  
Lock Nut  
**QTY (2)**



**P** 3/8" x 1.25"  
Carriage Bolts  
**QTY (4)**



**Q** 3/8"-16 Nylon  
Lock Nut  
**QTY (6)**



**R** 3/8" x 1"  
Carriage Bolts  
**QTY (2)**



**S** Spacer Tube  
**QTY (1)**

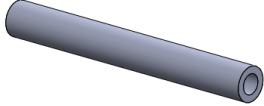

**T** 1/4"-20 x 5" Bolt  
**QTY (1)**



**U** 1/4"-20 Hex  
Nut  
**QTY (2)**



**V** 1/4" Split Lock  
Washer  
**QTY (1)**



**W** Medium Black  
Binder Clip  
**QTY (2)**



**X** Medium White  
Binder Clip  
**QTY (2)**



**Y** Small White  
Binder Clip  
**QTY (2)**



**Z** Bungee Cord  
90" long  
**QTY (1)**



**AA** Paper Targets  
**QTY (25)**



# Install (4) Stake Pads

## STEP 1

Install Stake Pads (M) onto each Leg (I) 4 places as shown

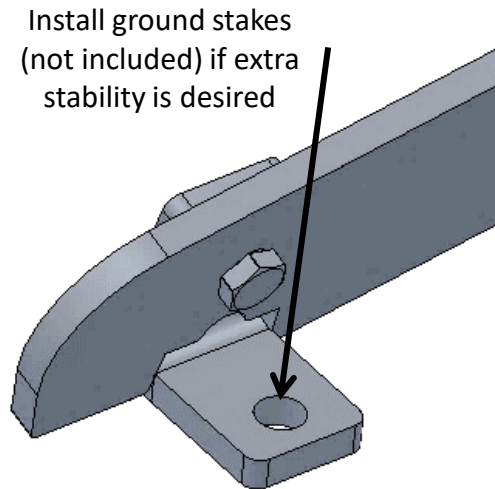
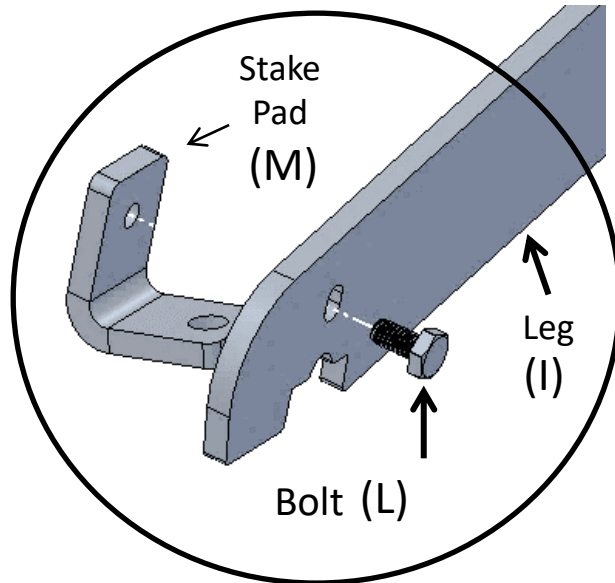
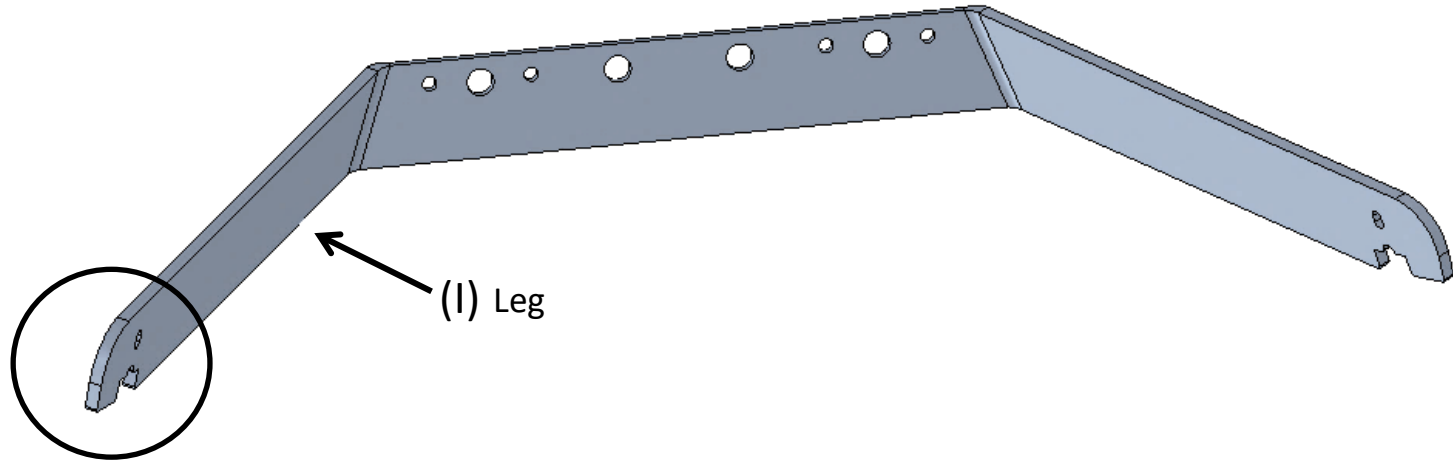

# Base Assembly

**TIP:**

Make sure the edge of the Quick Release Bracket (C) is parallel to the edge of the Leg (I) on each side before tightening hardware.

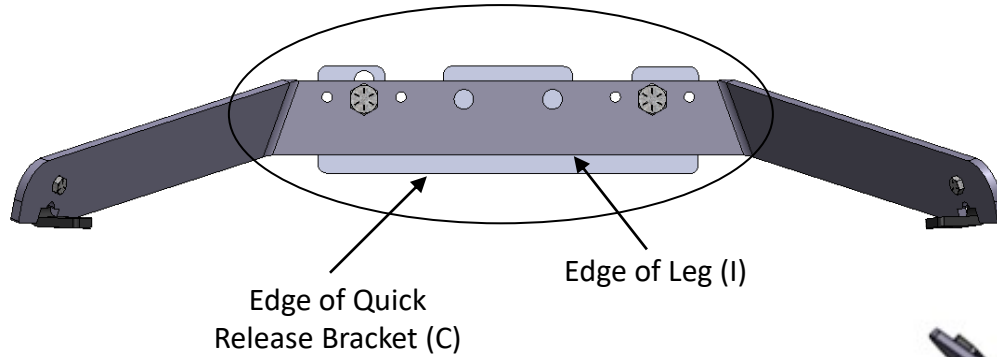

**STEP 1**

With Stake Pads (M) facing down, assemble the Quick Release Bracket (C) to the Legs (I) as shown

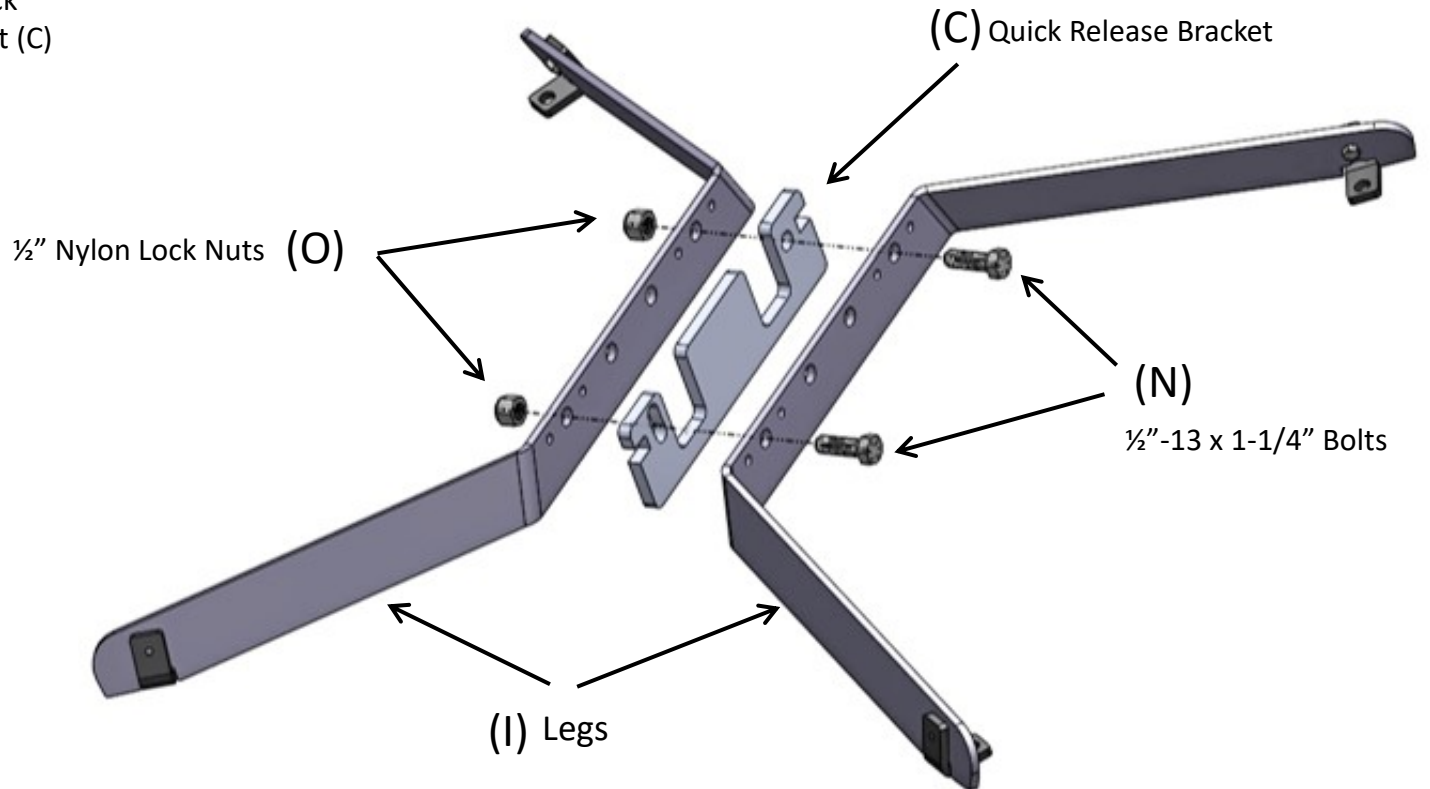

# Frame Assembly

## STEP 1

Assemble Motor Holder components to Top Beam as shown

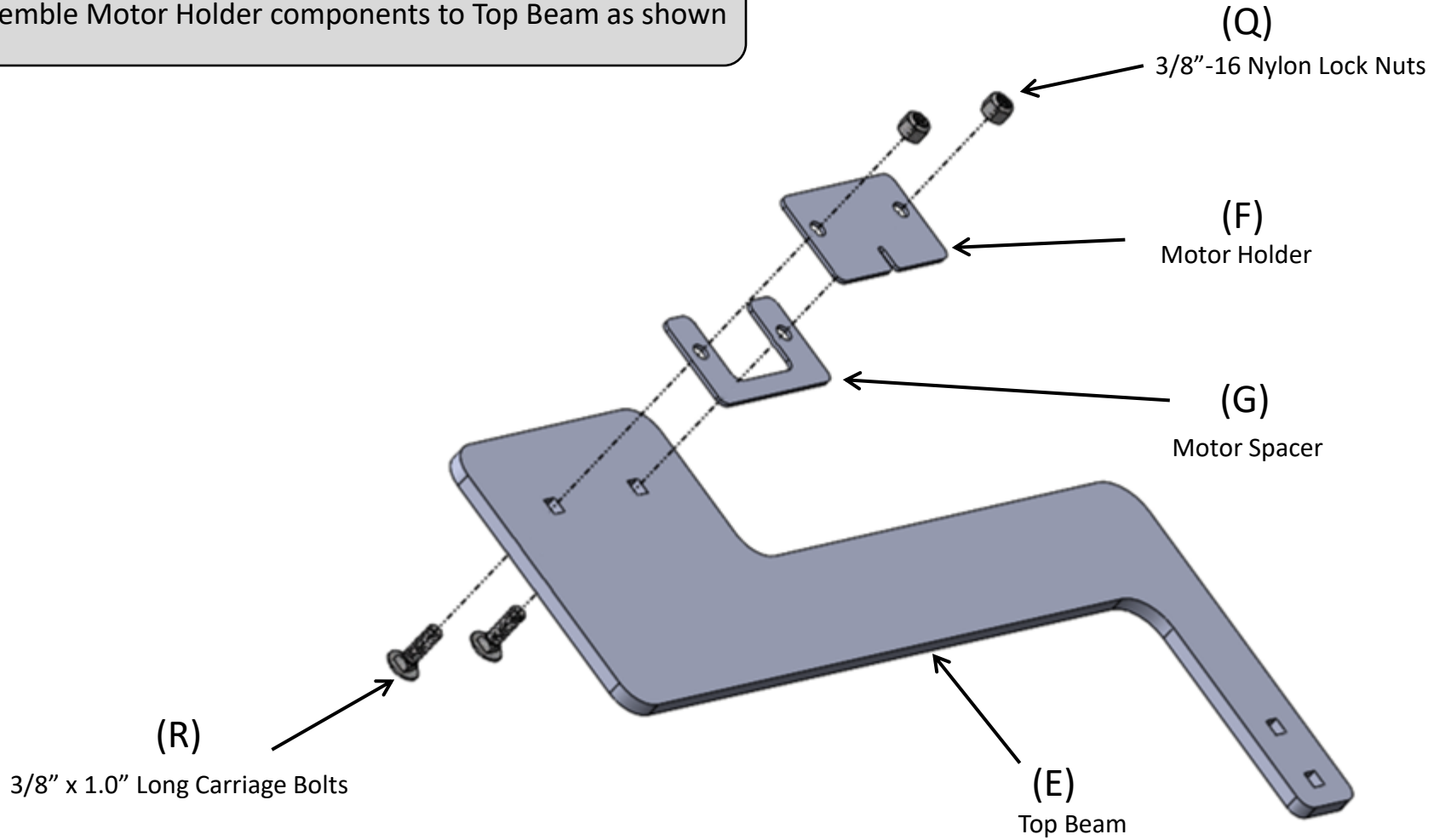

## STEP 1

Assemble Top Beam, Post and Base as shown.  
Keep mating edges flush when tightening hardware.

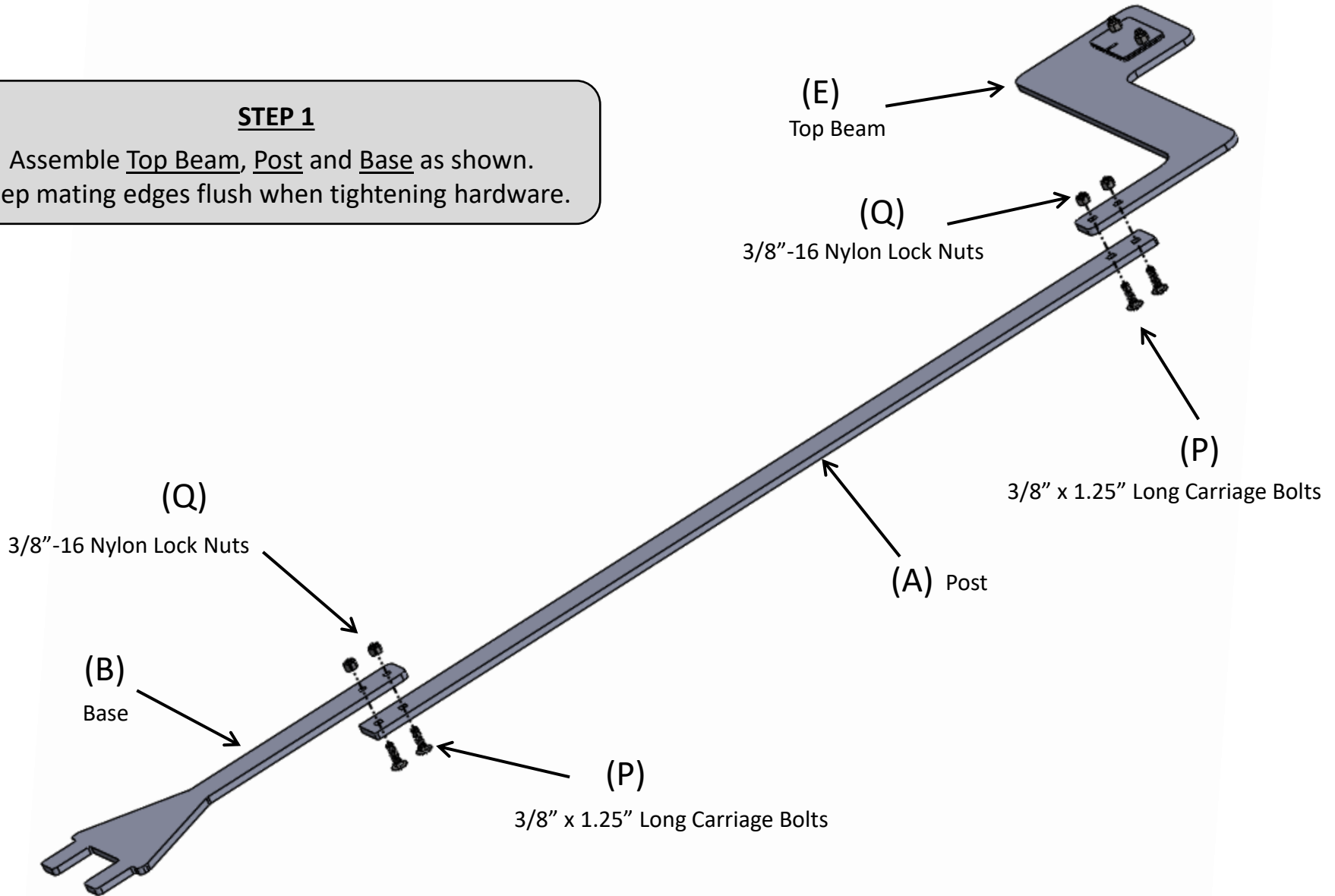

# Frame Assembly

**STEP 1** - Assemble Support Bar (J) and related components as shown

**STEP 2** - Insert Base (B) into Quick Release Bracket (C) as shown

**STEP 3** - Insert Support Bar (J) into Quick Release Bracket (C) as shown

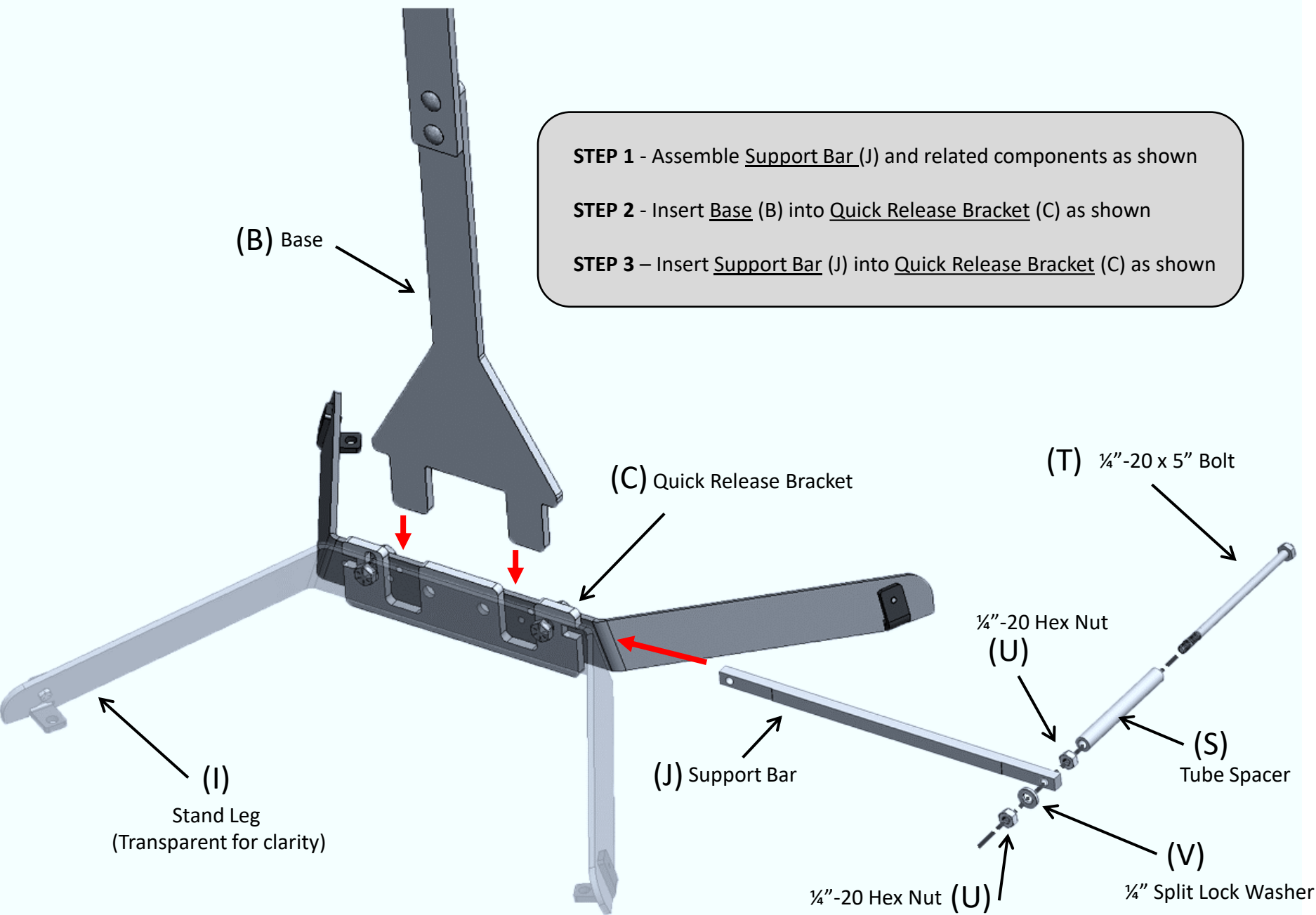



# Support Assembly

## STEP 1

Cut the Bungee Cord (Z) to 29" and tie one end to the Clamp (K) and the other end to the Bolt (T).

**Tip:** Tie the Bungee Cord in the gap between the Bolt (T) and the Tube Spacer (S)

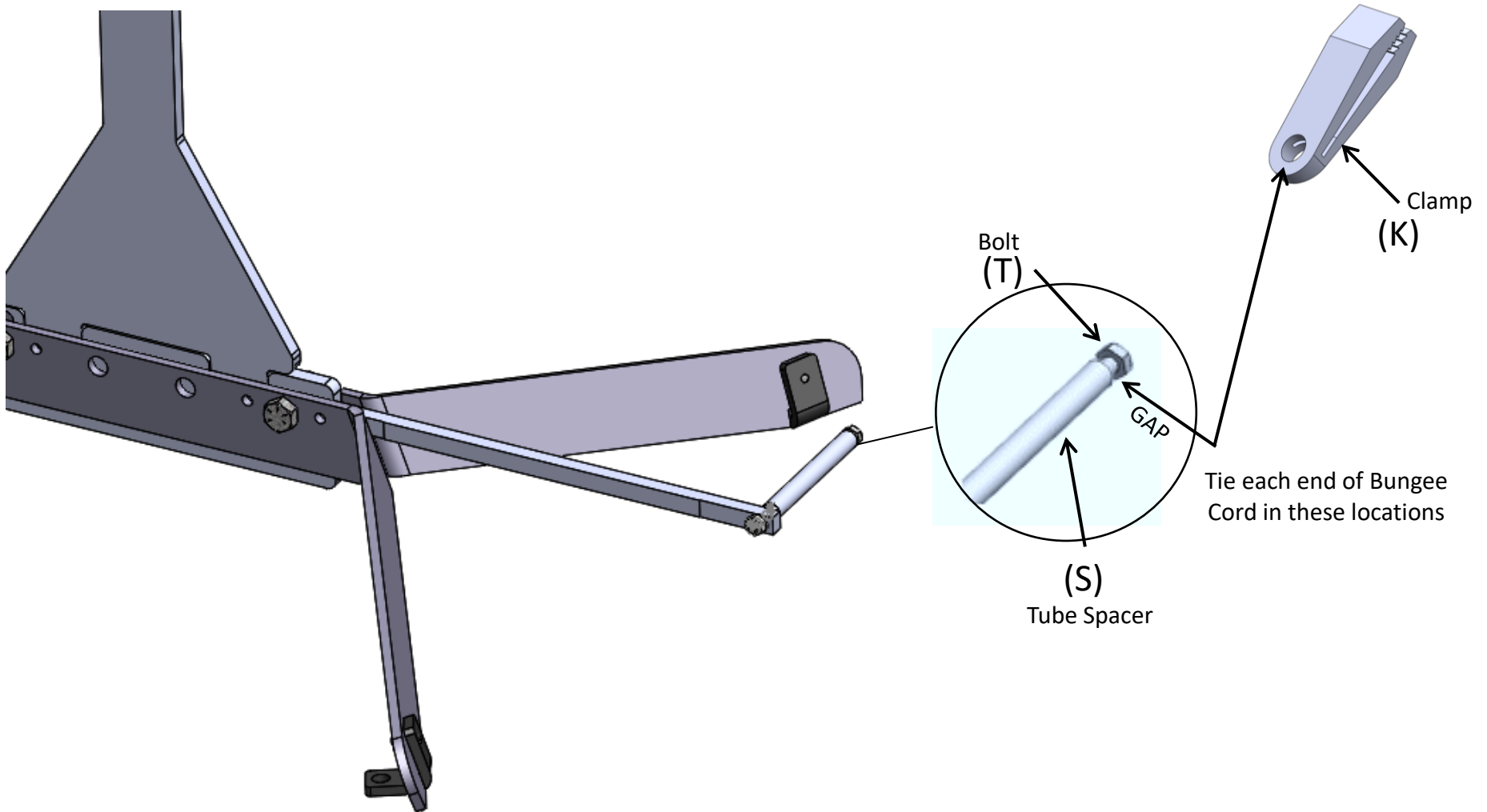

# Install Motor Assembly

## STEP 1

Insert the Motor Assembly (D) into the space between the Top Beam (E) and the Motor Holder (F) as shown.

